



TRANSPORTATION SPECS - Conventional Truck Cranes

AMERICAN MODEL 7530 - 125 TON CAPACITY

<u>COMPONENT WEIGHTS</u>	<u>LBS.</u>	<u>KGS.</u>	<u>BOOM TYPE 59H</u>	<u>LBS.</u>	<u>KGS.</u>
Complete Crane c/w 40' boom, counterweight, block and ball (5 axle) w/o booster	175,970	79 841	O.D. (tubular) 59 1/2" X 59 1/2"		
			<u>HAMMERHEAD 40' MIN. / 160' MAX.</u>		
**House, 4-axle carrier c/w outriggers, butt, gantry and cable (3)	126,200	57 260	Butt 20'	2,400	1 089
**House, 5 axle carrier c/w outriggers, butt, gantry and cable (4)	135,000	61 252	HH Tip 20' c/w Pendants	2,800	1 270
			<u>TAPERED TIP 60' MIN. / 220' MAX.</u>		
House, butt, gantry and cable	56,000	25 408			
Carrier (4 axle) w/o outriggers (1)	55,200	25 045	Butt 20'	2,400	1 089
Carrier (5 axle) w/o outriggers (2)	64,000	29 038	Tapered Tip 20' c/w Pendants	2,205	1 000
Main Counterweight	34,000	15 427	Transition 20' c/w Pendants	1,430	649
Certificate Weight		Varies by Unit	Insert 10' c/w Pendants	950	431
<u>ADDITIONAL INFORMATION</u>			Insert 20' c/w Pendants	1,700	771
125 Ton Block	3,520	1 597	Insert 40' c/w Pendants	2,950	1 338
15 Ton Ball	650	295	(See boom & jib section for composition details.)		
Front Outriggers c/w jacks & pads	7,500	3 403	<u>JIB NO. 9HL 80' MAX.</u>		
Rear Outriggers c/w jacks & pads	7,500	3 403	(10' and 20' sections)		
Tandem Booster	8,800	3 993			
Main Load Line (1" x 1,000')	1,850	839	OD (tubular) 27 3/4" x 27 3/4"		
Auxiliary Hoist Line (7/8" x 600')	852	387	80' c/w Pendants	3,700	1 679
Boom Suspension Line (3/4" x 430')	447	203			
<u>TRANSPORTATION</u>					
Average Driving Speed		50 km/hr			
Boom and counterweights are normally removed and hauled separately. Boom may be hauled 2 wide and 2 high.					
<u>Alberta</u>	<u>Weight</u>	<u>Trailer</u>	<u>COUNTERWEIGHTS TYPE KFLM</u>		
• Spring					
4 axle carrier c/w booster w/o outriggers	(1)	Drive	Main (10'4" x 4' x 4'10")	34,000	15 427
5 axle carrier w/o outriggers	(2)	Drive	Bumper (6'9" x 16" x 3'7")	7,500	3 403
• Spring Summer and Winter					
4 and 5 axle carrier		Drive			
House, butt and misc.		Haul*			
Both cranes may be hauled c/w butt and outriggers		Haul*			
<u>British Columbia</u>	<u>Weight</u>	<u>Trailer</u>			
• 5 axle carrier		Haul*			
4 axle carrier		Drive			
During spring c/w booster w/o outriggers		Drive			
• House, butt and misc.		Haul*			
<u>Saskatchewan</u>	<u>Weight</u>	<u>Trailer</u>			
• All Seasons	(3) or (4)	Haul w/o rear outrigger box			
*Trailer types dependent on seasonal weight allowance					
**Use 5 axle model when unit # unknown					

STERLING CRANE

AMERICAN 59S TAPERED TIP BOOM COMPOSITION

Boom Length In Feet	20 Ft. 59H Inner	10 Ft. 59S Center	20 Ft. 59S Center	40 Ft. 59S Center	20 Ft. 59S Outer Base	20 Ft. 59SH Tapered Tip
60	1	-	-	-	1	1
70	1	1	-	-	1	1
80	1	-	1	-	1	1
90	1	1	1	-	1	1
100	1	-	-	1	1	1
110	1	1	-	1	1	1
120	1	-	1	1	1	1
130	1	1	1	1	1	1
140	1	-	-	2	1	1
150	1	1	-	2	1	1
160	1	-	1	2	1	1
170	1	1	1	2	1	1
180	1	-	-	3	1	1
190	1	1	-	3	1	1
200	1	-	1	3	1	1

STERLING CRANE

AMERICAN 59S HAMMERHEAD BOOM COMPOSITION

Boom Length In Feet	20 Ft. 59H Inner	10 Ft. 59S Center	20 Ft. 59S Center	40 Ft. 59S Center	20 Ft. 59S Outer Base	Hammer-Head
40	1	-	-	-	1	1
50	1	1	-	-	1	1
60	1	-	1	-	1	1
70	1	1	1	-	1	1
80	1	-	-	1	1	1
90	1	1	-	1	1	1
100	1	-	1	1	1	1
110	1	1	1	1	1	1
120	1	-	-	2	1	1
130	1	1	-	2	1	1
140	1	-	1	2	1	1
150	1	1	1	2	1	1

STERLING CRANE

AMERICAN 59H TUBULAR TAPERED TIP BOOM COMPOSITION

Boom Length In Feet	20 Ft. 59SH Inner	10 Ft. 59H Center	20 Ft. 59H Center	40 Ft. 59H Center	20 Ft. 59H Outer Base	20 Ft. 59SH Tapered Tip
60	1	-	-	-	1	1
70	1	1	-	-	1	1
80	1	-	1	-	1	1
90	1	1	1	-	1	1
100	1	-	-	1	1	1
110	1	1	-	1	1	1
120	1	-	1	1	1	1
130	1	1	1	1	1	1
140	1	-	-	2	1	1
150	1	1	-	2	1	1
160	1	-	1	2	1	1
170	1	1	1	2	1	1
180	1	-	-	3	1	1
190	1	1	-	3	1	1
200	1	-	1	3	1	1
*210	1	1	1	3	1	1
*220	1	-	-	4	1	1

* Note: Model 7530 for erection of boom length above 200 ft., the boom foot supports and 7,500 lb. front bumper counterweight must be utilized.

STERLING CRANE

AMERICAN 59H TUBULAR HAMMERHEAD BOOM COMPOSITION

Boom Length In Feet	20 Ft. 59SH Inner	10 Ft. 59H Center	20 Ft. 59H Center	40 Ft. 59H Center	20 Ft. 59H Outer Base	Hammer-Head
40	1	-	-	-	1	1
50	1	1	-	-	1	1
60	1	-	1	-	1	1
70	1	1	1	-	1	1
80	1	-	-	1	1	1
90	1	1	-	1	1	1
100	1	-	1	1	1	1
110	1	1	1	1	1	1
120	1	-	-	2	1	1
130	1	1	-	2	1	1
140	1	-	1	2	1	1
150	1	1	1	2	1	1

Hammerhead Tip Offset 1.75'

STERLING CRANE

AMERICAN BOOM – SECTION WEIGHTS

Boom Sections c/w Pendants	47" S Tubular		59" S & H Tubular		77" S & H Tubular		92" HT & HD Tubular	
	<u>LBS.</u>	KGS.	<u>LBS.</u>	KGS.	<u>LBS.</u>	KGS.	<u>LBS.</u>	KGS.
Butt (Inner)	1,819	825	2,403	1 090	4,409	2 000	8,488	3 850
10 Foot	706	320	948	430	1,422	645	1,808	820
20 Foot	1,235	560	1,713	777	2,447	1 110	3,550	1 610
30 Foot	1,885	855						
40 Foot			2,921	1 325				
50 Foot					5,457	2 475	5,953	2 700
50 Foot XHD							7,297	3 310
Transition			1,433	650	2,999	1 360		
Taper Tip	2,095	950	2,205	1 000	3,417	1 550	11,133	5 050
Hammerhead			2,800	1 270	6,041	2 740		
Load Block			1,488	675 (60T)				

JIB SECTIONS		LBS.	KGS.
#7HL	30 Foot Basic Jib Assembly	1,259	570
	10' Section	199	90
	20' Section	386	175
#9HL	40 Foot Basic Jib Assembly	1,720	780
	10' Section	199	90
	20' Section	386	175
#15	30 Foot Basic Jib Assembly	1,951	885
	10' Section	298	135
#16HL	40 Foot Basic Jib Assembly	2,624	1 190
	10' Section	243	110
	20' Section	518	235
#30	25 Foot Basic Jib Assembly	TBD	TBD
	10' Section	TBD	TBD

STERLING CRANE

GENERAL DIMENSIONS

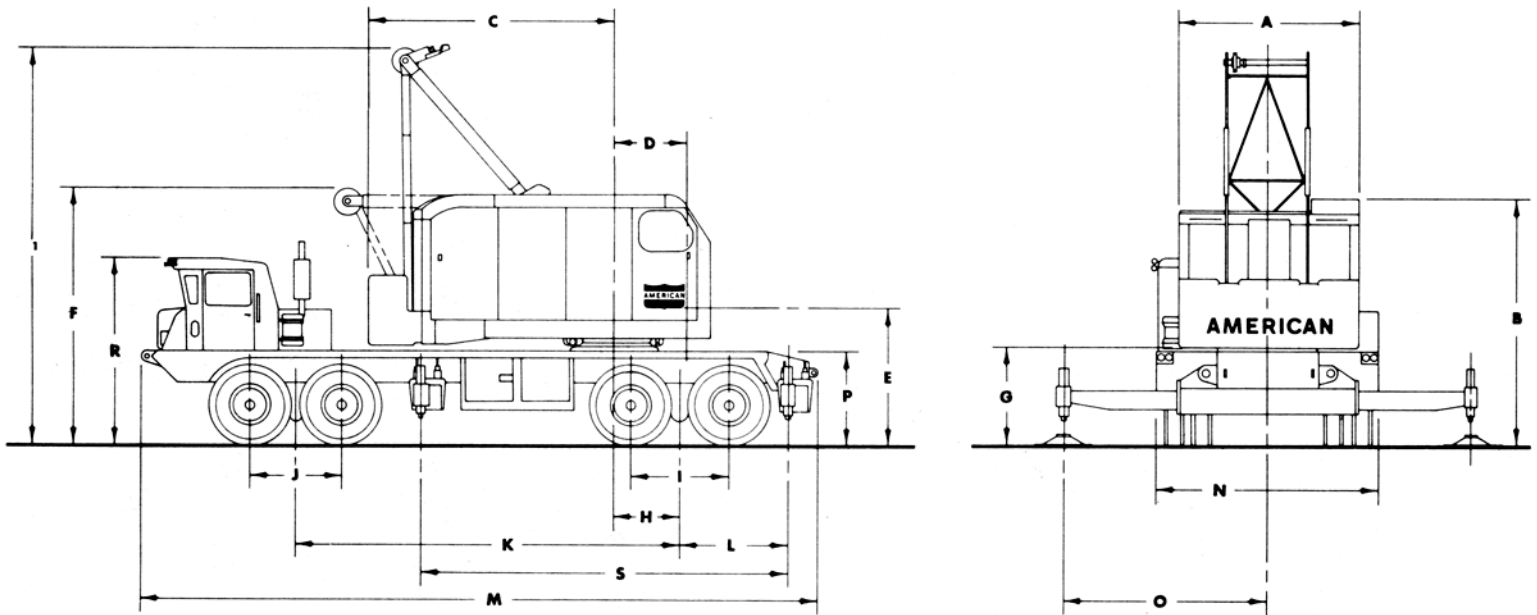

A. Width of cab	10'6"	K. Centerline of rear bogie to centerline of front bogie	19'10"
B. Height to top of cab	12' 11 1/4"	L. Centerline of rear bogie to centerline of rear outrigger	6' 5 1/2"
C. Tail Swing	14' 1 1/2"	M. Overall length	35'8"
D. Centerline of rotation to centerline of boom foot	4' 1 1/2"	N. Overall width	11'0"
E. Ground to centerline boom foot	6' 9 1/2"	O. Outriggers extended w/hydraulic outriggers	11'0"
F. Height over A-Frame (lowered)	13'5"	P. Height over mounting plate	4'5"
F1. Height over A-Frame (raised)	21' 9 1/4"	R. Height over carrier cab	9'3"
G. Ground to bottom of counterweight	5'2"	S. Centerline of rear outrigger to centerline of front outrigger	20' 4 1/2"
H. Centerline of rotation to centerline of rear bogie	3'6"	Turning radius	55'0"
I. Distance between rear axles	5'4"	Clearance (under rear equalizing beam)	7 3/4"
J. Distance between front axles	5'0"	Clearance (under rear differential)	15 1/4"